



© Copyright by Holland Pump Company 2003

6" Hydraulically Driven Submersible System
Model H6TMS - D4045D
Size 6" Trash, Materials, Sludge Pump

Holland® Pump Company
Corporate Office: 2610 Sidney Lanier Drive
Brunswick, Georgia 31525
Phone 912-466-0304
1-888-997-PUMP
www.hollandpump.com

PUMP SPECIFICATIONS

- Size:** 6" Trash, Materials, Sludge Pump
- Volute:** Fabricated Steel (optional stainless steel and special abrasion resistant steel volutes are available)
- Impeller:** Recessed vortex, 6 Vane. Handles 3.5" diameter compressible spherical solids. (optional stainless steel or special abrasion resistant steel impellers are available)
- Impeller Shaft:** Stainless steel
- Seal:** Rotary Mechanical, oil-lubricated, carbon & ceramic (optional tungsten carbide or silicon carbide seals are available option)

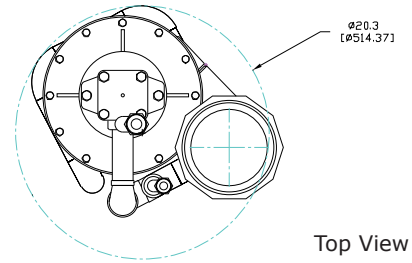

Top View

Hydraulic System

- Hydraulic Reservoir level:** 50 gallon capacity with twin 10 micron spin on oil filter
- Biodegradable Oil:** Furnished standard (optional petroleum based hydraulic oil available)
- Hydraulic Pump:** Denison vane type positive displacement pump with pilot operated Denison relief valve
- Hydraulic Motor:** Vickers vane type positive displacement motor
- Heat Exchanger:** Double row, SCH 40 pipe with integral intake basket (optional engine mounted oil cooler available)
- Hydraulic Hose:** 50' set of SAE 100R2, two wire braid high-pressure hose
- Pump Head Fail Safe Pressure Relief System:** Available as option to protect system against improper connection or interruption of biodegradable oil flow from pump head to power unit

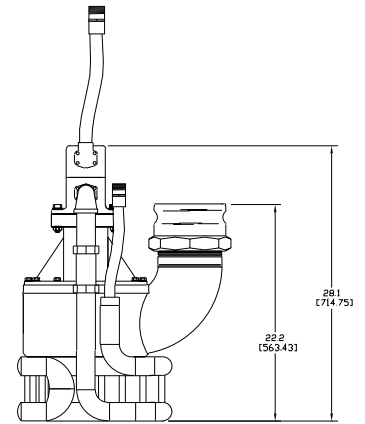

Holland 6" Trash Materials, Sludge Pump

ENGINE SPECIFICATIONS

- Model:** John Deere 4045D
- Type:** 4 Cylinder, 4 Stroke, Naturally Aspirated, Liquid Cooled Diesel Engine
- Displacement:** 4.5L (276 cu.in.)
- Governor:** Mechanical
- Lubrications:** Forced Circulation
- Air Cleaner:** Dry Type with Replaceable Element
- Lube Oil Capacity:** 3.5 U.S. Gallons
- Coolant Capacity:** 5 U.S. Gallons
- Fuel Tank:** Integral 114 U.S. Gallon Capacity (#2 Diesel Fuel)
- Full Load Operating Time:** 60 Hours Minimum @ 2000 PSI
- Starter:** 12 Volt, 2.0 kW

H6TMS @ 2000 PSI	Capacity of Pump in U.S. Gallons per Minute (gpm) (Continuous Performance)
20' Head	1200
10' Head	1400

Standard Features: SAE 3 Flywheel Housing, SAE 10" Clutch, SAE B Pump Adaptor, Murphy Safety Shut Down System
Covering: Engine Temperature, Engine Oil Pressure, Hydraulic Oil Level & Hydraulic Oil Temperature
Optional Features: Auto-Oiler with Engine Oil Shutdown, Site or DOT Highway Trailer, Automatic Remote Start and Stop, HANS (Holland Automatic Notification System), Full Instrument Package Covering: Air Filter, Fuel Filter, RPM, Radiator Coolant Level, Fuel Level

John Deere Published Performance: Maximum Continuous Power: 76 BHP (57kW) @ 2500 RPM

Specifications subject to change without notice



© Copyright by Holland Pump Company 2003

6" Hydraulically Driven Submersible System
Model H6TMS - D4045D
Size 6" Trash, Materials, Sludge Pump

Holland® Pump Company
Corporate Office: 2610 Sidney Lanier Drive
Brunswick, Georgia 31525
Phone 912-466-0304
1-888-997-PUMP
www.hollandpump.com

Approximate Dimensions
Powered by John Deere 4045D Engine
Single Axle Trailer Shown

	Skid Base	DOT Trailer	Pump
Net Weight (lbs)	2568	2968	195
Shipping Weight (lbs)	N/A	N/A	N/A
Export Crate Size (cu.ft)	198	N/A	16

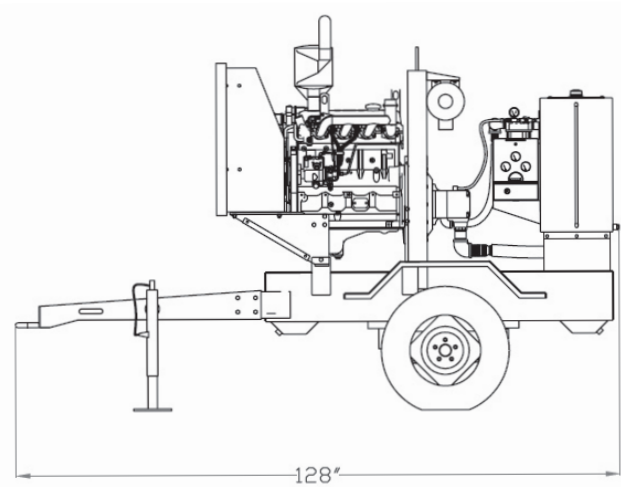
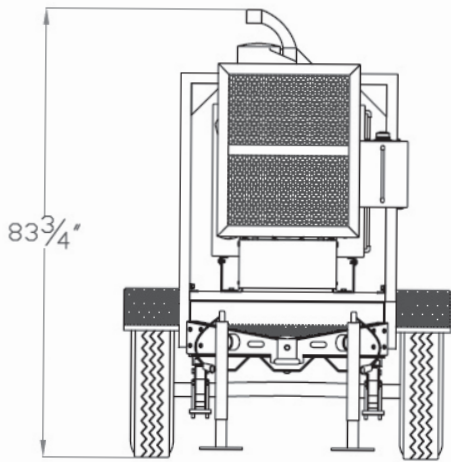

Performance Curve Model: H6TMS - D4045D
Size: 6" Trash, Materials, Sludge Pump

TOTAL HEAD
PSI FT

