

4" Hydraulically Driven Submersible System
Model H4TP - P404C22
Size 4" Trash Pump

Holland® Pump Company
Corporate Office: 2610 Sidney Lanier Drive
Brunswick, Georgia 31525
Phone 912-466-0304
1-888-997-PUMP
www.hollandpump.com

PUMP SPECIFICATIONS

Size: 4" Trash Pump
Volute: Fabricated steel with horizontal discharge (optional stainless steel and special abrasion resistant steel volutes are available)
Impeller: Semi-open, 3 Vane. Handles 3" diameter spherical compressible solids, optional stainless steel and special abrasion resistant steel impellers are available)
Impeller Shaft: Stainless steel
Seal: Rotary Mechanical, oil-lubricated, carbon & ceramic (optional tungsten carbide and silicon carbide seals are available)

Hydraulic System
Hydraulic Reservoir Level: 30 gallon capacity with single 10 micron spin-on oil filter
Biodegradable Oil: Furnished standard (optional petroleum base hydraulic oil available)

Hydraulic Pump: Denison vane type positive displacement pump with pilot operated Denison relief valve
Hydraulic Motor: Vickers vane type positive displacement motor
Heat Exchanger: Double row, SCH 40 pipe with integral intake basket (optional engine mounted oil cooler available)
Hydraulic Hose: 50' set of SAE 100R2, two wire braid high-pressure hose
Pump Head Fail Safe Pressure Relief System: Available as an option to protect system against improper connection or interruption of biodegradable oil flow from pump head to power unit

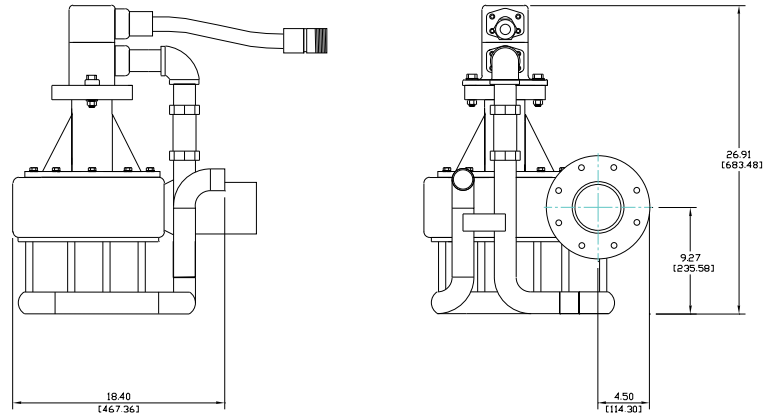

Holland 4" Trash Pump

ENGINE SPECIFICATIONS

Model: Perkins, 400 Series, 404C-22
Type: 4 Cylinder, 4 Stroke, Naturally Aspirated, Liquid Cooled, Diesel Engine
Displacement: 2.2L (134cu.in.)
Governor: Mechanical
Lubrications: Forced Circulation
Air Cleaner: Dry Type with Replaceable Element
Lube Oil Capacity: 2 U.S. Gallons
Coolant Capacity: 2.5 U.S. Gallons
Fuel Tank: Integral 68 U.S. Gallon Capacity (#2 Diesel Fuel)
Full Load Operating Time: 60 Hours Minimum @ 2000 PSI
Starter: 12 Volt, 2.0 kW
Standard Features: Skid, SAE 4 Flywheel Housing, SAE 7 1/2" Flywheel, SAE B Pump Adaptor, System Covering: Engine Temperature and Low Oil Pressure
Optional Features: Auto-Oiler with Engine Oil Shutdown, Site or DOT Highway Trailer, Automatic Remote Start and Stop, HANS (Holland Automatic Notification System), Full Instrument Package Covering: Air Filter, Fuel Filter, RPM, Radiator Coolant Level, Fuel Level

| H4TP @ 2000 PSI | Capacity of Pump in U.S. Gallons per Minute (gpm) for Continuous Performance |
|-----------------|--|
| 20' Head | 700 |
| 10' Head | 800 |

Perkins Published Performance: Maximum Continuous Power: 38 BHP (28.5kW) @ 2000 RPM

Specifications subject to change without notice



© Copyright by Holland Pump Company 2003

4" Hydraulically Driven Submersible System
Model H4TP - P404C22
Size 4" Trash Pump

Holland® Pump Company
Corporate Office: 2610 Sidney Lanier Drive
Brunswick, Georgia 31525
Phone 912-466-0304
1-888-997-PUMP
www.hollandpump.com

Approximate Dimensions
Powered by Perkins 404C-22 Diesel Engine, Optional
Single Axle Trailer Shown

| | Skid Base | DOT Trailer | Pump |
|----------------------------|-----------|-------------|------|
| Net Weight (lbs) | 2202 | 2502 | 130 |
| Shipping Weight (lbs) | 2302 | N/A | N/A |
| Export Crate Size (cu. ft) | 107 | N/A | 6 |

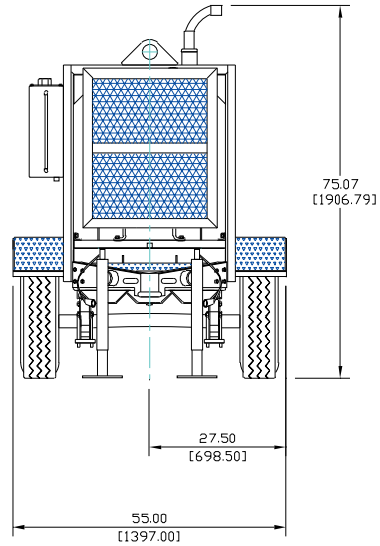
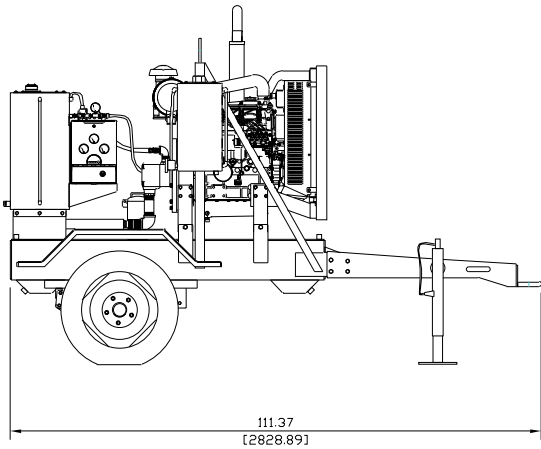

TOTAL HEAD

Performance Curve Model: H4TP - P404C22
Size: 4" Trash Pump

