



© Copyright by Holland Pump Company 2011

12" Rotary Pump  
 Model W12R - D4045TF280  
 Size 12" Rotary Pump

Holland® Pump Company  
 Corporate Office: 2610 Sidney Lanier Drive  
 Brunswick, Georgia 31525  
 Phone 912-466-0304  
 1-888-997-PUMP  
 www.hollandpump.com

## PUMP SPECIFICATIONS

**Size:** 12" Rotary Pump  
**Pump:** LobePro GL531, Class 30 gray cast iron casing and smooth end cover  
**Solids:** Handles up to 2.5" compressible soft solids  
**Rated Capacities:** 2656 GPM (355 CFM) @ 500 RPM  
**Displacement:** 531 US gallons per 100 revolutions  
**Working Pressure:** to 87 psi  
**Flange Connections:** 10" Flat Face ANSI, 150 lbs. Flange connections included  
**Rated Speed:** 0 - 500 RPM. Consult factory for recommended operating speeds  
**Rotors in:** Helix three wing rotors, NBR standard, other materials available on request  
**Wet-Ends:** Standard in Gray Cast Iron  
**Shaft Material:** Alloy Steel, AISI 4140  
**Rear Door:** Contains 2 bearings and two mechanical seals to prevent shaft deflection. The door is readily removable for changing lobes, mechanical sea cartridges and wear plate.  
**Gear Material:** AGMA Class 8, SAE 1045  
**Mechanical Seals:** Duronit vs. Duronit cartridge seal  
**Vibration:** Pumps and motors operate at any point within their operating range without undue noise and vibration  
**Top and Bottom Housing Segments:** ASTM A48 Class 30 gray cast iron coated with ceramic epoxy for wear resistance; options include Ryton® and Tungsten Carbide. Segments adjustable based on wear.  
**Optional Equipment:** Site or DOT highway trailer, automatic oiler system to add engine makeup oil as required with low oil shutdown, Holland Automatic Notification System (HANS) with low vacuum shutdown system (LOV), automatic remote start and stop controller

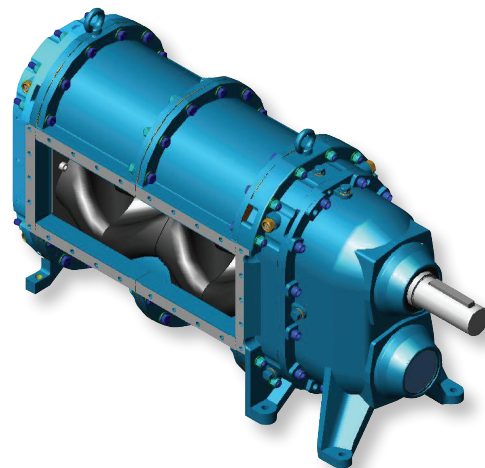

## GEAR SPECIFICATIONS

PTO Gear reduction 3.66 to 1

## ENGINE SPECIFICATIONS

**Model:** John Deere 4045TF280, Tier 3  
**Type:** 4 Cylinder, 4 Stroke, Turbocharge Aspirated, Liquid Cooled Diesel Engine  
**Displacement:** 4.5L (275 cu.in.)  
**Governor:** Mechanical  
**Lubrications:** Forced Circulation  
**Air Cleaner:** Dry Type with Replaceable Element  
**Lube Oil Capacity:** 3.5 U.S. Gallons (13.2L)  
**Coolant Capacity:** 2.25 U.S. Gallons (8.5L)  
**Fuel Tank:** Integral 114 U.S. Gallon Capacity (#2 Diesel Fuel)  
**Full Load Operating Time:** 60 Hours Minimum @ 2000 PSI  
**Starter:** 12 Volt, 2.0 kW  
**Standard Features:** Cast Iron Engine Block, SAE 10" Flywheel and SAE 3 Flywheel Housing, Ecoplus Oil and Fuel Filters, Glow Plug Starting Aid, Integral Inlet and Manifold, Gear Driven Coolant Pump, Cast Iron Exhaust Manifold with Center Side Outlet, Standard Instrument Panel: Engine Temperature and Low Oil Pressure with optional Gauge, Key Start, and Hour Meter  
**Optional Features:** Site or DOT Highway Trailer, Automatic Remote Start and Stop, HANS (Holland Automatic Notification System), NEMA 4 Instrument Package Covering: Air Filter, Fuel Filter, Engine Temperature, Fuel Level, Engine Oil Pressure, Hour Meter, Amp Meter, Hydraulic Oil Pressure  
**Coupling:** Dodge  
**John Deere Published Performance:**  
 Maximum Continuous Power: 72 BHP (54kW) @ 2400 RPM  
 Maximum Intermittent Power: 80 BHP (60kW) @ 2400 RPM



© Copyright by Holland Pump Company 2011

12" Rotary Pump  
Model W12R - D4045 TF280  
Size 12" Rotary Pump

Holland® Pump Company  
Corporate Office: 2610 Sidney Lanier Drive  
Brunswick, Georgia 31525  
Phone 912-466-0304  
1-888-997-PUMP  
www.hollandpump.com

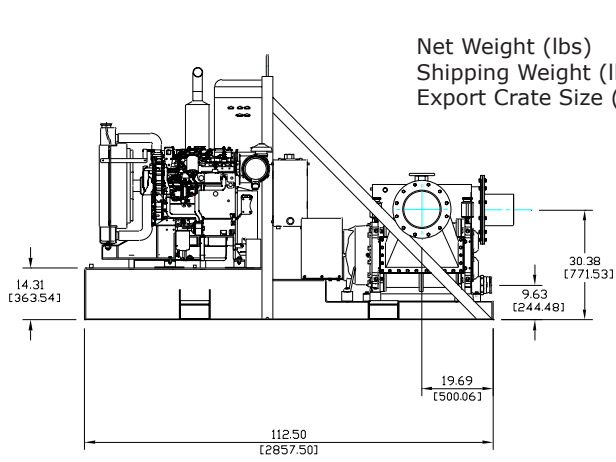
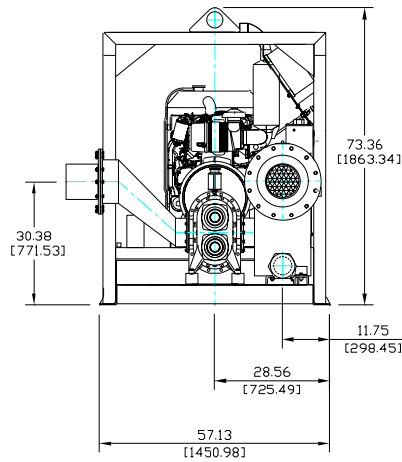

Net Weight (lbs)	5300
Shipping Weight (lbs)	5450
Export Crate Size (cu. ft)	285

Skid Base

U.S. Gallons  
Per Minute (GPM)

Performance Curve Model: W12R - JD4045  
TF280 Size: 12" Rotary Pump

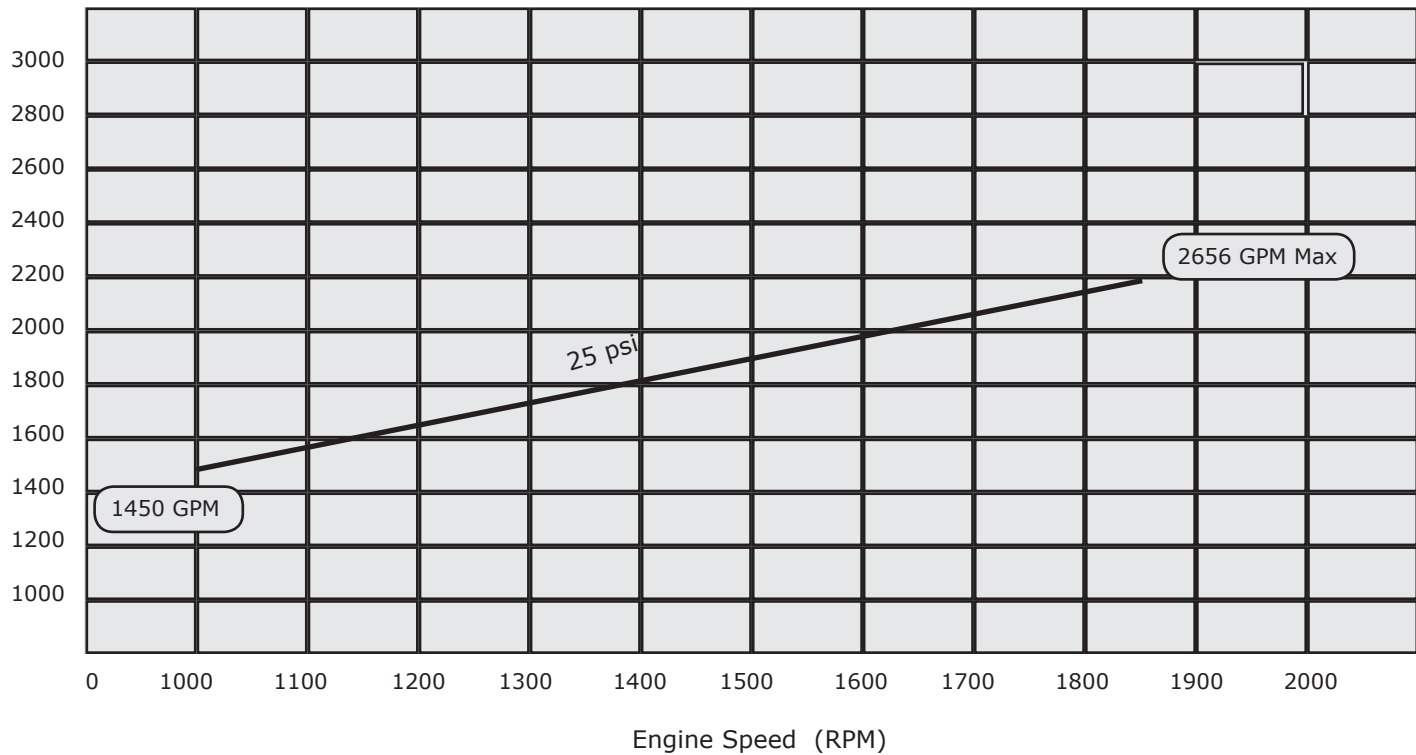

The above curve is based on pumping clear water at 62 degrees with no lift required and no restrictions in the discharge.