



# Why Rotary Lobe Pumps are Effective in Wastewater Treatment Plants

Bill Blodgett, Holland Pump Manufacturing

This analysis explores the benefits of using rotary lobe pump technology in suction lift applications in comparison to centrifugal and progressive cavity pumps.

**M**odern rotary lobe pump technology has come a long way since its introduction in the early 1970s. Developed as a self-priming pumping system for use in agricultural material transfer, rotary lobe pumps have proven themselves to be an economical and efficient solution for viscous fluid transfer applications. As such, they are well suited to many wastewater applications.

## The Case for Rotary Lobe Pumps vs. Centrifugals

In order to operate effectively, centrifugal pumps require the operator to carefully monitor the pump's performance. The following are some advantages to using rotary lobe pumps in suction lift situations.

*Unlike centrifugal pumps, rotary lobe pumps have no need to operate at a best efficiency point.*

Centrifugal pumps require adherence to several factors which contribute to operating at the best efficiency point (BEP). In order for a centrifugal pump to operate at its best efficiency point, it must be operated to match its manufacturer's suggested system curve.

As Bill McNally says, "Ideally, a pump would run at its best efficiency point all of the time, but we seldom hit ideal conditions. As you move away from the BEP, the shaft will deflect and the pump will experience some vibration. You'll have to check with your pump manufacturer to see how far

you can safely deviate from the BEP and still get satisfactory operation (a maximum of 10 [percent] either side is typical)."<sup>1</sup>

Furthermore, as stated in *Pumps and Systems*, "operation far from the BEP will result in users obtaining only a small fraction of the design life of their equipment."<sup>2</sup>

***Rotary lobe pumps have the ability to pump materials with high levels of entrained air, all while maintaining prime.***

On the other hand, rotary lobe pumps are equally efficient at any speed.

*Unlike centrifugal pumps, the net positive suction head (NPSH) required by a rotary lobe pump is constant.*

NPSH required by a centrifugal pump increases as the volume pumped increases. As suction lift decreases, the volume pumped by a centrifugal pump increases and both  $NPSH_A$  and  $NPSH_R$  increase, which is good.

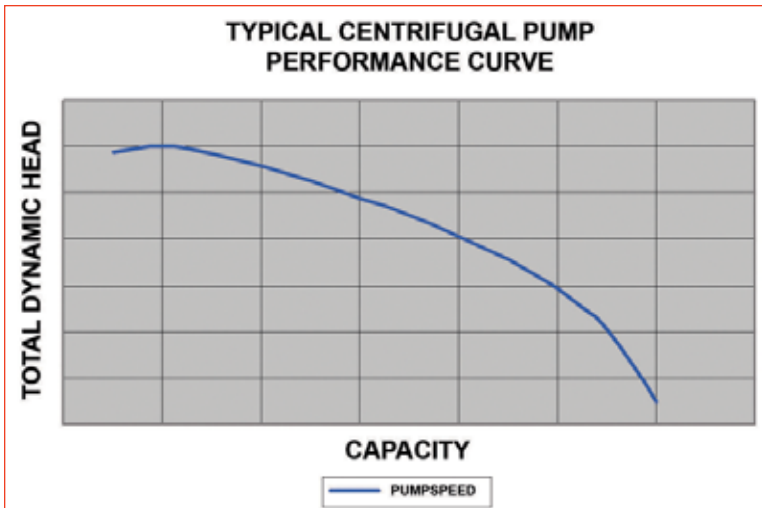

In a centrifugal pump, as total dynamic head increases (in feet), capacity decreases (gpm).

However, what is not obvious is that the changes in  $NPSH_A$  and  $NPSH_R$  are not necessarily equal, and the pump may wind up operating far from its BEP if the suction lift changes substantially.

Centrifugal pumps are perfectly capable of pumping more volume than the NPSH available allows. A case in point is a pump we tested that pumped 11,000-gpm at 7-ft lift. However, the manufacturer's curve indicated that at a 7-ft lift the NPSH required would only permit pumping 8,000-gpm. Pumping in excess of the permitted volume, of course, results in cavitation.

To avoid this, as the suction lift changes, say, 5-ft or more, adjustment to head or speed are usually required to keep the pump operating within a 10 percent range of its best efficient point. Rotary lobe pumps can create a vacuum of 28-in of Hg and thus are able to provide suction lifts up to 25-ft. The output of a rotary lobe pump is not affected by changes in suction lift within its operating range.

*Unlike centrifugal pumps, the output of a positive displacement pump, such as a rotary lobe pump, is largely unaffected by head or viscosity.*

The volume pumped by a centrifugal pump is dependent on head and viscosity. If in an application these vary dynamically, it will be difficult to keep a centrifugal pump operating close to its BEP.

*Rotary lobe pumps do not require separating air from water.*

Rotary lobe pumps have the ability to pump materials with high levels of entrained air, all while maintaining prime. Any entrained air in a system can cause a centrifugal pump to cavitate or lose prime.

## The Case for Rotary Lobe Pumps vs. Progressive Cavity Pumps

Progressive cavity pumps, the rotary lobe pump's positive displacement cousin, are well suited to wastewater treatment pumping applications, but they do have some disadvantages. The following are some advantages to using rotary lobe pumps in place of progressive cavity applications with proper suction and discharge piping.

*Rotary lobe pumps have the ability to run dry.*

One drawback to progressive cavity pumps is their inability to tolerate run-dry situations. According to the Water Environment Federation, "If it is run dry, the pump will be damaged in a matter of minutes."<sup>3</sup>

Due to the close tolerances necessary for the rotor and stator to perform efficiently, a run dry situation can cause significant damage to the pump requiring costly repairs.

Rotary lobe pumps have the ability to run dry for a period of time without adverse effects. In addition as long as there is some material flow, rotary lobe pumps have the ability to maintain vacuum even in intermittent run dry conditions with proper suction and discharge piping.

*Cost advantages attributed to simplicity of rotary lobe design.*

Progressive cavity pumps, being of a larger design, require significantly more area for installation and maintenance. This additional needed space includes the disassembly dimension. The disassembly dimension is the area required to allow for the lateral removal of the rotor from the stator housing. In addition,

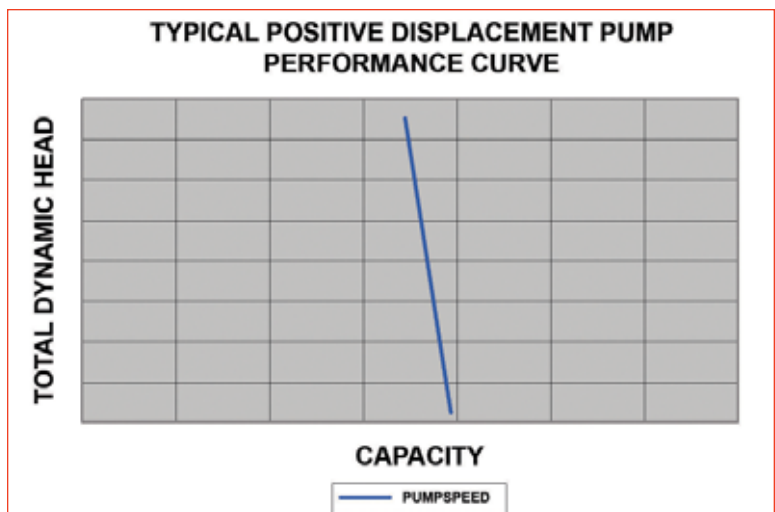

As total dynamic head increases (in feet), rotary lobe pumps are able to maintain an almost constant capacity (gpm) because they are positive displacement pumps.

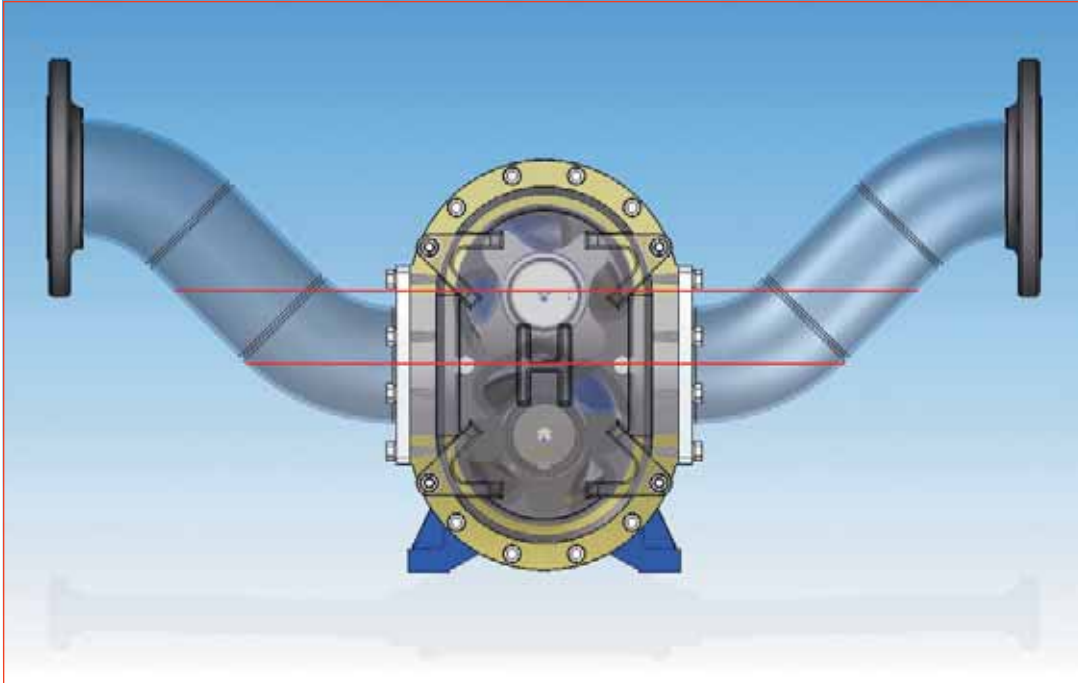

Suction and discharge piping configurations aid in priming rotary lobe pumps. Here, indicated in red, are typical fluid levels maintained within the quench chamber in order to assist priming.



**PumpCalcs**

Sponsored by  
**PUMPS & SYSTEMS**

$$\sum_{n \geq 0} \frac{\text{online + calculators}^2}{\text{mathematical proofs}} \times \binom{n}{\text{users}} + \sqrt{\frac{f(n)}{\text{projects, reports}}} = \text{PumpCalcs Logo}$$

## PUMP CALCULATIONS SIMPLIFIED. AS EASY AS POINT & CLICK.

- Numerous, easy-to-use calculators online.
- Guided calculators provide insight and analysis on complicated problems.
- It's free! No registration is required to perform calculations.
- Mathematical proofs are generated, and your results can be saved.
- Calculators have user-contributed, real-world examples.
- Automatic conversion and support for English and Metric units.

Visit [www.pump-zone.com](http://www.pump-zone.com)

tion, all piping must be removed in order for the repair to take place.

Rotary lobe pump units are compact and occupy less than one-third of the space required for a progressive cavity pump. Rotary lobe pumps can also be configured with the motor mounted overhead, further reducing their footprint. Maintenance costs are reduced as their lobes, mechanical seals and wear plates can be exchanged in place without the need to disconnect the suction and discharge piping – reducing downtime and maintenance expenses.

## Rotary Lobe Pump Technology is Advancing

Modern rotary lobe pump designs continue to make steady progress. New technologies include maintenance in place designs, elastomer coated lobes, helical multi-vaned lobes, enhanced wear part coatings (including the use of ceramic epoxy, ryton® and tungsten carbide) and the introduction of replaceable mechanical seal cartridges.

These materials have made the rotary pump an effective, efficient and affordable alternative to centrifugal and progressive cavity pumps.

P&S

**As long as there is some material flow, rotary lobe pumps have the ability to maintain vacuum even in intermittent run dry conditions with proper suction and discharge piping.**

### References

1. McNally, Bill. *McNally Institute Website*, accessed at [www.mcnallyinstitute.com/02-html/2-03.html](http://www.mcnallyinstitute.com/02-html/2-03.html).
2. Delaney, Kevin. "As Discussed: Much Remains To Be Done." *Pumps and Systems* (January 2005): 13-15.
3. Water Environment Federation. *Operation of Municipal Wastewater Treatment Plants*. 1996. *Pumping of Wastewater and Sludge*.

Bill Blodgett is the president of Holland Pump Manufacturing, Inc., 2610 Sidney Lanier Drive, Brunswick, GA 31525, 912-466-0304, Fax: 912-466-0086, [www.hollandpump.com](http://www.hollandpump.com).

## Rotodynamic (Centrifugal) Slurry Pumps for Nomenclature, Definitions, Applications and Operation

*Believed to be the first of its kind, this landmark standard includes comprehensive information on:*

- Slurry pump types
- Types of slurries
- Slurry limitations
- Slurry solids' effect on pumps
- Pumping of froth
- Pump wear
- Application

### Order NOW!

This standard, HI product code A128, is available from the Hydraulic Institute for \$195.00. It is available in secure PDF format via online server, or can be ordered in hard copy from the HI e-store at [www.pumps.org](http://www.pumps.org). The online service provides virtually instant access to HI pump standards as PDF documents on a worldwide basis. **Be sure to mention promotion code PC-Slurry1105.**



**Hydraulic**  
INSTITUTE  
*Creating Pump Standards Since 1917*

**Visit the HI e-Store at [www.pumps.org](http://www.pumps.org)**

circle 157 on card or go to [psfreeinfo.com](http://psfreeinfo.com)